

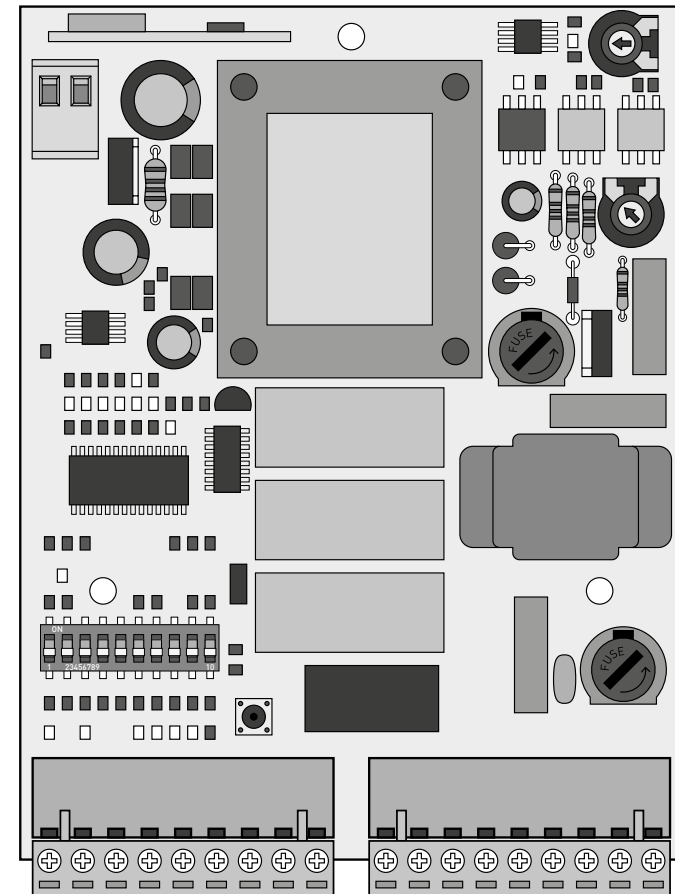

MC102

USER / INSTALLER MANUAL

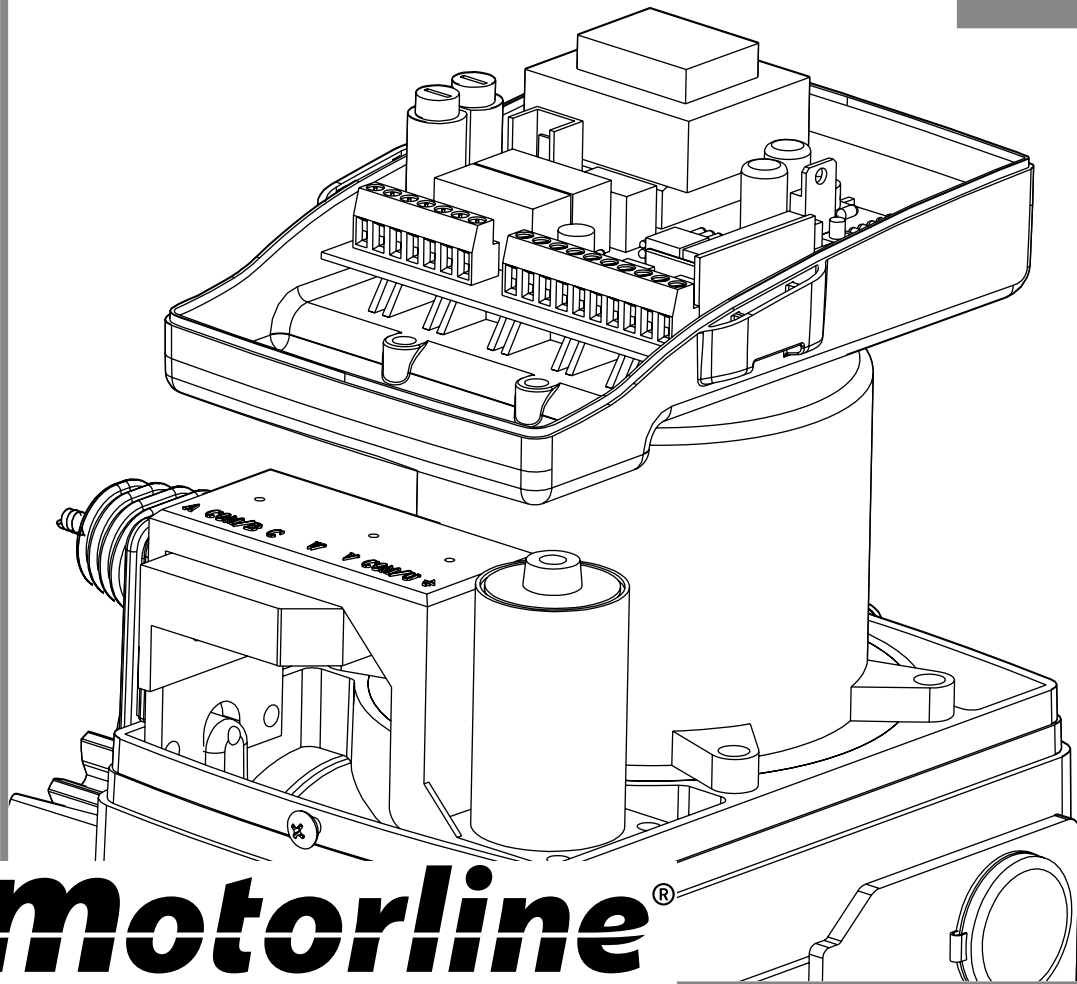

00. CONTENT



ÍNDEX

| | |
|---|----|
| 01. SAFETY INSTRUCTIONS | |
| STANDARDS TO FOLLOW | 1B |
| 02. THE CONTROL BOARD | |
| TECHNICAL SPECIFICATIONS | 2A |
| PROGRAMMING PRE-RECOMENDATIONS | 2B |
| 03. DIPPERS | |
| DIPPERS FUNCTION'S BOARD | 3A |
| 04. CONFIGURATION | |
| INSTALATION PROBLEM | 4A |
| 05. COMPONENT TEST | |
| CAPACITATOR SCHEME | 5B |
| 06. TROUBLESHOOTING | |
| FINAL CONSUMERS INSTRUCTIONS | 6 |
| INSTRUCTIONS FOR SPECIALIZED INSTALLERS | 6 |
| 07. WIRING DIAGRAM | |
| CONTROL BOARD COMPONENT CONNECTION | 7 |

01. SAFETY INSTRUCTIONS

STANDARDS TO FOLLOW

ATTENTION:

| | |
|---|--|
|  | This product is certified in accordance with European Community (EC) safety standards. |
| RoHS | This product complies with Directive 2011/65/EU of the European Parliament and of the Council, of 8 June 2011, on the restriction of the use of certain hazardous substances in electrical and electronic equipment. |
|  | (Applicable in countries with recycling systems). This marking on the product or literature indicates that the product and electronic accessories (eg. Charger, USB cable, electronic material, controls, etc.) should not be disposed of as other household waste at the end of its useful life. To avoid possible harm to the environment or human health resulting from the uncontrolled disposal of waste, separate these items from other types of waste and recycle them responsibly to promote the sustainable reuse of material resources. Home users should contact the dealer where they purchased this product or the National Environment Agency for details on where and how they can take these items for environmentally safe recycling. Business users should contact their vendor and check the terms and conditions of the purchase agreement. This product and its electronic accessories should not be mixed with other commercial waste. |
|  | This marking indicates that the product and electronic accessories (eg. charger, USB cable, electronic material, controls, etc.) are susceptible to electric shock by direct or indirect contact with electricity. Be cautious when handling the product and observe all safety procedures in this manual. |

- It is important for your safety that these instructions are followed.
- Keep these instructions in a safe place for future reference.
- The **ELECTROCELOS S.A.** is not responsible for the improper use of the product, or other use than that for which it was designed.
- The **ELECTROCELOS S.A.** is not responsible if safety standards were not taken into account when installing the equipment, or for any deformation that may occur.
- The **ELECTROCELOS S.A.** is not responsible for insecurity and malfunction of the product when used with components that were not sold by the them.
- This product was designed and manufactured strictly for the use indicated in this manual.
- This control board is not appropriate for inflammable or explosive environments.
- Any other use not expressly indicated may damage the product and/or can cause physical and property damages, and will void the warranty.
- Do not make any changes to the automation components and/or their accessories.
- Control board for indoor use with 110V/230V connection.
- Keep remote controls away from children, to prevent the automated system from being activated involuntarily.
- The customer shall not, under any circumstances, attempt to repair or tune the automatism. Must call qualified technician only.
- The installer must have certified professional knowledge at the level of mechanical assemblies in doors and gates and control board programming. He should also be able to perform electrical connections in compliance with all applicable regulations.
- The installer should inform the customer how to handle the product in an emergency and provide him the manual.

02. THE CONTROL BOARD

TECHNICAL SPECIFICATIONS

| | 110V | 230V |
|--------------------------------|-------------------------|------------------|
| • Power supply | AC 110V 50/60Hz | AC 230V 50/60Hz |
| • Lightbulb's output | AC110V 40W máx. | AC230V 40W máx. |
| • Motor's output | AC110V 750W máx. | AC230V 750W máx. |
| • Auxiliary accessories output | AC24V 8W máx. | |
| • Working temperature | -20°C a +50°C | |
| • Incorporated Radio Receptor | 433,92 Mhz | |
| • OP Transmitters | 12 bits ou Rolling Code | |
| • Maximum memory capacity | 200 Códigos | |

• CONNECTOR'S DESCRIPTION

| | |
|----|---|
| M2 | <ul style="list-style-type: none"> 01 • Closing limit-switch input signal (NC) 02 • Opening limit-switch input signal (NC) 03 • Open/close transmitter button's input (NA) 04 • Safety device input - complete direction inversion (NC) 05 • Pedestrian transmitter button's input (NC) 06 • Safety device input - 2 seconds inversion (NC) 07 • Safety device input common / STARTs 08 • Power supply output for accessories 0V 09 • Power supply output for accessories 24V AC - 8W máx. |
| M1 | <ul style="list-style-type: none"> 10 • Light bulb connection's output (AC230V 40W máx.) 11 • Light bulb connection's output - common (AC230V 40W máx.) 12 • Light bulb connection's output or courtesy light (AC230V 40W máx.) 13 • Motor's output - Opening 14 • Motor's output - Common 15 • Motor's output - Closing 16 • 230V line input (phase) 17 • Not used 18 • 230V line input (neutral) |
| M3 | <ul style="list-style-type: none"> 19 • Antenna mass input 20 • Antenna hot pole input |
| M4 | <ul style="list-style-type: none"> 21 • Place Shunt for motors up to 500kg (included) 22 • Remove Shunt for motors up to 500kg |

02. THE CONTROL BOARD

PROGRAMMING PRE-RECOMMENDATIONS





Before proceeding to the control board configuration, note the following points listed in the table below in order to better understand the control board function:

| | |
|--------------|--|
| M2 connector | <p>Limit-switches :</p> <p>01 and 02 • Make sure that the limit switches connections are synchronized with the FCH and FAP LEDs (see explanation in page 4A at point 3). Test it by moving the automatism limit-switch's spring by hand and see if the it lights up the FCH and FAP LEDs in the correct ways (FCH LED turns off with a closing signal and the FAP LED turns off with the opening signal).</p> <p>Safety circuits:</p> <p>04 • This circuit allows the connection of all types of safety devices such as photocells, safety bands, etc. This device operates only in the gate closing and it reverses the automatism's movement,when activated.</p> <p>06 • This circuit allows the connection of all types of safety devices such as photocells, safety bands, etc. This device acts as both the closing and the opening and it reverses the automatism's movement for 2 seconds,when activated.</p> |
| M1 Connector | <p>Light bulb:</p> <p>10 • This is an intermittent output and must be used lightbulbs that do not have electrical circuit because the output itself is programmed to create a flashing effect on the bulb (apply only a lightbulb witg socket and bulb). It does quick flashes when it is opening, it remains off when paused and it flashes slowly during closure. If you want that, during the pause time, it remains lit continuously, read the last paragraph on page 05A.</p> <p>12 • Output for light bulb or courtesy light, according to what is selected in Dipper 3 (see p. 3A).</p> <p>When used in lightbulb mode, it must be equipped with an electrical circuit that transforms this continuous output in flashing mode. This will only work during the automatism work time.</p> <p>When used in courtesy light mode, you should be aware of the light maximum consumption capacity because the output only supports 40W.</p> <p>If the consumption is higher, intersperse a power relay.</p> <p>Capacitator:</p> <p>13 and 15 • You should connect the capacitator between the outputs 13 and 15.</p> |

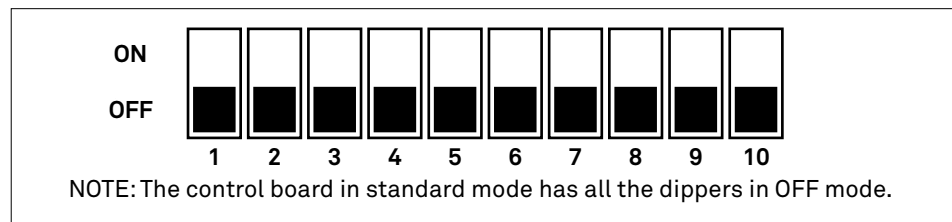
03. DIPPERS





DIPPERS FUNCTION'S BOARD



| | ON (cima) | OFF (baixo) |
|-------|--|--|
| Dip 1 | The SOFT STOP function is triggered only after the control board receives the limit switch signal. It continues the movement for another 3 seconds. | The SOFT STOP function is triggered 3 seconds before the control board receives the limit-switch signal. When it receives, it immediately stops the automatism. |
| Dip 2 | Enables the SOFT START and SOFT STOP functions. | Disables the SOFT START and SOFT STOP functions. |
| Dip 3 | Enables the lightbulb and courtesy light output (M1 - terminal 11 and 12). Only during the motor's work time. | Enables courtesy light output (M1 - terminal 11 and 12) during the work time, pause time and an additional 3 minutes after closing. |
| Dip 4 | <p>4 5 Dip 4 OFF Dip 5 OFF</p>   <p>Step-by-step function with self-closing.</p> <ul style="list-style-type: none"> • During the opening accepts transmitter signals. • When the gate stops, does the timing and automatically closes. • If it receives a transmitter signal during closing, it reverses. • In pause time, it anticipates the closing. | <p>4 5 Dip 4 ON Dip 5 ON</p>   <p>Step-by-step function with self-closing, if the gate is stopped at the limit-switch's end.</p> <ul style="list-style-type: none"> • If the gate is stopped by a transmitter signal during the opening and closing course, it will be stopped until new order. |

03. DIPPERS

DIPPERS FUNCTION'S BOARD

| | | |
|-----------------|--|--|
| Dip 4 and Dip 5 | <p>4 5 Dip 4 OFF Dip 5 ON</p>   <p>Normal Step-by-step function without automatic closure. Gate opens or closes only if it receives transmitter signals. The behavior will be open-stop-close-stop-open...</p> | <p>4 5 Dip 4 ON Dip 5 OFF</p>   <p>Condominium function with automatic locking: Transmitters aren't accepted during opening and during closing it reverses direction and stops only at the end of the course. Transmitters are not accepted during the pause time.</p> |
| | <p>Dip 6</p> <p>Disables the reading of the opening limit-switch.</p> <p>NOTE: The 6 and 7 dippers avoid shunt placement, when the control board is applied in engines, which don't use limit-switches.</p> | <p>Enables the reading of the opening limit-switch.</p> |
| Dip 7 | <p>Disables the reading of the closing limit-switch.</p> | <p>Enables the reading of the closing limit-switch.</p> |
| Dip 8 | <p>Disables the M2/04 safety device's reading.</p> <p>NOTE: The dipper 8 avoids shunt placement, when the control board is applied in engines which don't use safety devices connected to 04 terminal of M2 connector.</p> | <p>Enables the M2/04 safety device's reading.</p> |
| Dip 9 | <p>Programming the work and pause time.</p> | <p>Normal functioning.</p> |
| | <p>NOTE: The dipper 9 should only be used to trigger the work and pause time configuration function. When the programming is complete, put it in OFF mode.</p> | |
| Dip 10 | <p>Enables anti-crushing function.</p> | <p>Disables anti-crushing function.</p> |

04. CONFIGURATION

INSTALLATION PROCESS

• TOTAL OPENING AND TRANSMITTER PROGRAMMING

01 • Place all the dippers in OFF position (down). In case of not using safety device at 4/M2 terminal (ex: photocells), place the dipper 8 in ON to disable it.

02 • Unlock the engine, place the gate in the middle position and re-lock the engine.

03 • Connect the power to the control board check if the limit-switches are activated correctly.

When wiring the limit-switches at 01 and 02 terminals, the FCH and FAP LEDs will remain lit. When moving the spring manually towards closing position, the FCH LED must turn off and when moving it towards opening position, the FAP LED must go off too. If the LEDs are turning off switched (FCH for opening and FAP for closing), swap the wires from 01 and 02 terminals.

04 • Make a START with a help of a wire by connecting the 3 and 7 terminals with the wire tips and check if the motor is running in the correct direction. When the gate starts moving to one side, move the limit-switches spring towards the gate's movement direction and it should stop. If it doesn't, pull it the other way and it will stop. Swap the motor wires (13 and 15 terminals from M1 connector) to put in the right direction.

05 • When the gate is synchronized with the limit-switch correct direction, make a START again between 3 and 7 terminals. The gate will begin to move to one side. Let it reaches the closed position electrically.

06 • When the gate comes to a closed position, press the P1 button located on the control board for 2 seconds until the CODE LED (see connection diagram page 07.A) stays lit. Right away, press the transmitter button you want to be the total opening key (choose between 1, 3 and 4 buttons shown in the images at the right).

NOTE: When the transmitter button is pressed, the CODE LED must blink, indicating it is receiving the code.

07 • Release the first button and then press the button number 2 to memorize the pedestrian opening button. Release it and wait for the CODE LED turns off.

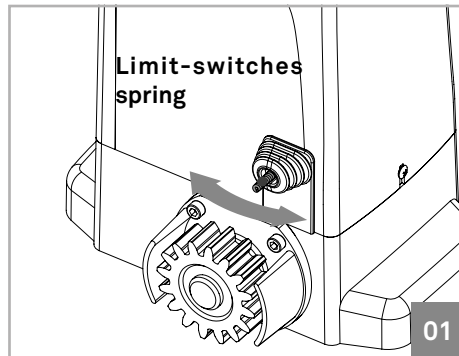

04. CONFIGURATION

INSTALLATION PROCESS

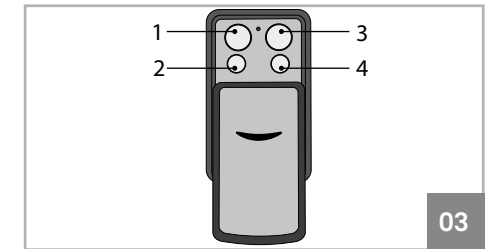
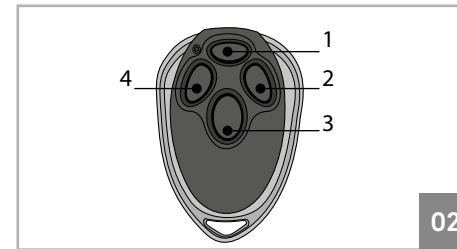

If you try to program button number 2 as total open button, the control board will recognize it but performs the maneuvers without idling opening.

NOTE: If you select a button other than the n° 2 for pedestrian opening, the control board will recognize it as complete opening button (but without idling opening), which means it will override the first pressed button. If the pedestrian opening is not wished, do not press the n°2 button and wait for the CODE LED to turn off.

08 • The transmitter is now configured.

NOTE: After setting up a transmitter type, the control board will only accept transmitters from the same type, it means, if the first transmitter is Rolling Code, they must all be Rolling Code for the central to accept them.

To program other transmitters, repeat the steps from n°6.

• ERASE ALL THE TRANSMITTERS FROM THE CONTROL BOARD

01 • With the gate closed, hold the P1 button continuously.

The CODE LED lights up and wait for 15 seconds until it turns off.

Release the P1 and the LED will flash twice that signals the MEMORY RESET success.

• PROGRAMMING THE WORKING TIME AND ENGINE'S PAUSE

01 • With the gate closed, place the dipper 9 to "ON", press transmitter (already programmed) / START and the gate will start to open.

02 • When the gate stops at the open position (opening limit-switch is enabled), wait for the desired pause time (*) and give a new START to close. This waited time represents the time that the engine will wait between the end of the opening maneuver and the the automatic closure's start. This automatic closure will only happen if the 4 and 5 dippers are in the selected positions to activate it (see page 03).

When the gate reaches the closed position, change the Dipper 9 to OFF to finish programming and CODE LED will blink and go off. If the dipper is leaved ON, the programming won't be finalized.

04. CONFIGURATION

INSTALLATION PROCESS

If the control board blocks and a RESET is needed, follow these steps:

- 01 • Turn off the control board's power.
- 02 • Put Dipper 9 to ON.
- 03 • Reconnect the control board to the power supply and put the dipper 9 to OFF.

• PROGRAMMING THE PEDESTRIAN WORK TIME

01 • With the gate in closed mode put the Dipper 9 ON.

02 • Press the button n°2 to start opening the gate. Upon reaching the desired position, press again the button to stop the engine. Wait the desired pause time and give a new START to close. This waited time represents the time that the engine will wait between the end of the pedonal's opening maneuver and the the automatic closure's start. Nearing the limit-switch's end, the engine will stop.

03 • The setting is completed, place the dipper 9 in OFF to finalize and close the pedestrian programming.

• FORCE AND SENSITIVITY REGULATION (ANTI-CRUSHING)

The control board has 2 trimmers (rotary knobs):

RV1 - Allows the engine sensitivity regulation (increases sensitivity by rotating it in the clockwise direction);

RV2 - Allows the engine power regulation (increases the force by rotating in the clockwise direction);

Warning: To use anti-crush function (recommended for small gates), it is necessary to regulate first the engine's power with the trimmer RV2 and right after the sensitivity with trimmer RV1.

If you change the engine's power after performing a Working Time and Engine Pause programming , a new one is going to be needed.

• ILLUMINATED LIGHTBULB IN PAUSE TIME (10 AND 11 TERMINALS)

01 • If you wish to activate this function, when programming work time and engine's pause (page 04.B), at the point 2, do the following operation from (*).

• Press the pedestrian transmitter button while the gate is paused, between the opening and closing.

NOTE: In case of using the 11 and 12 terminals for the lightbulb, the DIP3 must be OFF and the Lightbulb must have a circuit board to make the lamp to blink.

05. COMPONENT TEST

CAPACITATOR SCHEME

To detect which components have problems during an sliding automatism installation, sometimes is necessary to conduct tests with a direct connection to a 230V power supply. For this, is necessary to interpose a capacitor on the connection to the motor can work (check the capacitor type to be used in the product manual).

In the diagram below is shown how this connection must be made and how to merge the different component wires.

NOTE:

- To perform the tests its not needed to remove the automatism from the place, because this way you can understand if the automatism, directly connected to the power, can function correctly.
- The order of capacitor wires linked with the automatism wires are not important, as long as the wires stay linked, one to the Brown wire and the other to the Black.
- The common must always be connected to the power supply.
- To reverse the automatism functioning direction, swap the Black wire with the automatism Brown wire.

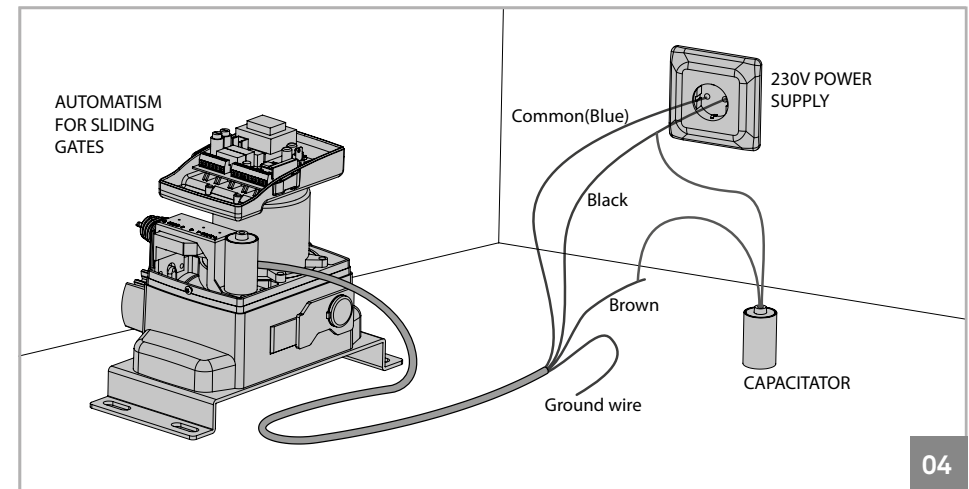

04



All tests must be performed by skilled technicians due to serious danger associated with the misuse of electrical systems!

06. TROUBLESHOOTING

FINAL CONSUMERS INSTRUCTIONS

SPECIALIZED TECHNICIANS INSTRUCTIONS

| Anomaly | Procedure | Behavior | Procedure II | Discovering the origin of the problem | | | |
|--------------------------------------|--|---------------------------------------|---|---|--|--|--|
| • Door doesn't work | • Make sure you have 230V power supply connected to control board and if it is working properly. | • Still not working | • Consult a qualified MOTORLINE technician. | 1 • Open control board and check if it has 230V power supply; 2 • Check input fuses; | 3 • Disconnect the motor from control board and test them by connecting directly to power supply in order to find out if they have problems | (see page 11.A). 4 • If the motor works, the problem is on the control board. Pull it out and send it to our MOTORLINE technical services | for diagnosis; 5 • If the motor doesn't work, remove them from installation site and send to our MOTORLINE technical services for diagnosis. |
| • Motor doesn't move but makes noise | • Unlock motor and move the gate by hand to check for mechanical problems on the movement | • Encountered problems? | • Consult an experienced gate expert. | 1 • Check all motion axis and associated motion systems related with the motor and the gate to find out what is the problem. | | | |
| | | • The gate moves easily? | • Consult a qualified MOTORLINE technician. | 1 • Check capacitors, testing operator with new capacitors; 2 • If capacitors are not the problem, disconnect motors from control board and test them by connecting directly to power supply in order to find out if they have problems (see page 09.A); | 3 • If the motors work, the problem is from control board. Pull it out and send it to our MOTORLINE technical services for diagnosis; | 4 • If the motors doesn't work, remove them from installation site and send to our MOTORLINE technical services for diagnosis. | |
| • Motor opens but doesn't close | • Unlock motor and move the gate by hand to closed position. Lock motor again and turn off power supply for 5 seconds. Reconnect it and send order to open gate using transmitter. | • Gate opened but didn't close again. | 1 • Check if there is any obstacle in front of the photocells; 2 • Check if any of the control devices (key selector, push button, video intercom, etc.) of the gate are jammed and sending permanent signal to control unit; 3 • Consult a qualified MOTORLINE technician. | All MOTORLINE control boards have LEDs that easily allow to conclude which devices are with anomalies. All safety devices LEDs (DS) in normal situations remain On. All "START" circuits LEDs in normal situations remain Off. If LEDs devices are not all On, there is some security systems malfunction (photocells, safety edges), etc. If "START" circuits LEDs are turn On, there is a control device sending permanent signal. | A) SECURITY SYSTEMS:: 1 • Close with a shunt all safety systems on the control board (check manual of the control board in question). If the automated system starts working normally check for the problematic device. 2 • Remove one shunt at a time until you find the malfunction device . 3 • Replace it for a functional device and check if the motor works correctly with all the other devices. If you find another one | defective, follow the same steps until you find all the problems. B) SISTEMAS DE START: 1 • Disconnect all wires from START terminal input (terminal 3 of CN3 connector). 2 • If the LED turned Off, try reconnecting one device at a time until you find the defective device. | NOTE: In case procedures described in sections A) and B) don't result, remove control board and send to our technical services for diagnosis. |
| • Gate doesn't make complete route | • Unlock motor and move gate by hand to check for mechanical problems on the gate. | • Encountered problems? | • Consult an experienced gate expert. | 1 • Check all motion axis and associated motion systems related with the gate to find out what is the problem. | | | |
| | | • The gate moves easily? | • Consult a qualified MOTORLINE technician. | 1 • Check capacitors, testing with new capacitors; 2 • If capacitors are not the problem, disconnect motor from control board and test it by connecting directly to power supply in order to find out if it is broken; 3 • If the motor doesn't work, remove it from installation site and send to our MOTORLINE technical services for diagnosis. | 4 • If motor work well and move gate at full force during the entire course, the problem is from controller. Set force using trimmer on the board. Make a new working time programming , giving sufficient time for opening and closing with appropriate force (page 08.B). 5 • If this doesn't work, remove control unit and send it to | MOTORLINE technical services services. | NOTE: Setting force of the controller should be sufficient to make the gate open and close without stopping, but should stop and invert with a little effort from a person. In case of safety systems failure, the gate shall never cause physical damaged to obstacles (vehicles, people, etc.). |

07. WIRING DIAGRAM

CONTROL BOARD COMPONENT CONNECTION

